



CAD File: N:\Project\2024\240249\Drawings\240249CLP700.dgn

Date Plotted: 01-08-2024 2:49:43 PM

**CITY OF MARIBYRNONG  
ADVERTISED PLAN**



Wurundjeri Woiwurrung Country  
56 Down Street, Collingwood, VIC 3066  
Email: info@onemilegrid.com.au Web: www.onemilegrid.com.au  
Phone (03) 9939 8250

Scale  
1:1000 @ A3

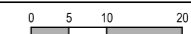

Drawing Title  
ASTRON SERVICE STATION, MARIBYRNONG  
PROPOSED JOLT EV CHARGING SPACE  
SITE CONTEXT PLAN

Designed CM	Approved SF	Melway Ref 28 C8
----------------	----------------	---------------------

Project Number 240249	Drawing Number CLP700	Revision C
--------------------------	--------------------------	---------------

Copyright  
This document may only be used for its commissioned purpose. No part of this document may be reproduced, modified or transmitted without the written authority of onemilegrid. Unauthorised use of this document in any form is prohibited.

onemilegrid operates from Wurundjeri Woiwurrung Country of the Kulin nation.  
We acknowledge and extend our appreciation to the Wurundjeri People, the Traditional Owners of the land.  
We pay our respects to leaders and elders past, present and emerging for they hold the memories,  
the traditions, the culture, and the hopes of all Wurundjeri Peoples.

Aerial Photography  
Aerial photography provided by Nearmap

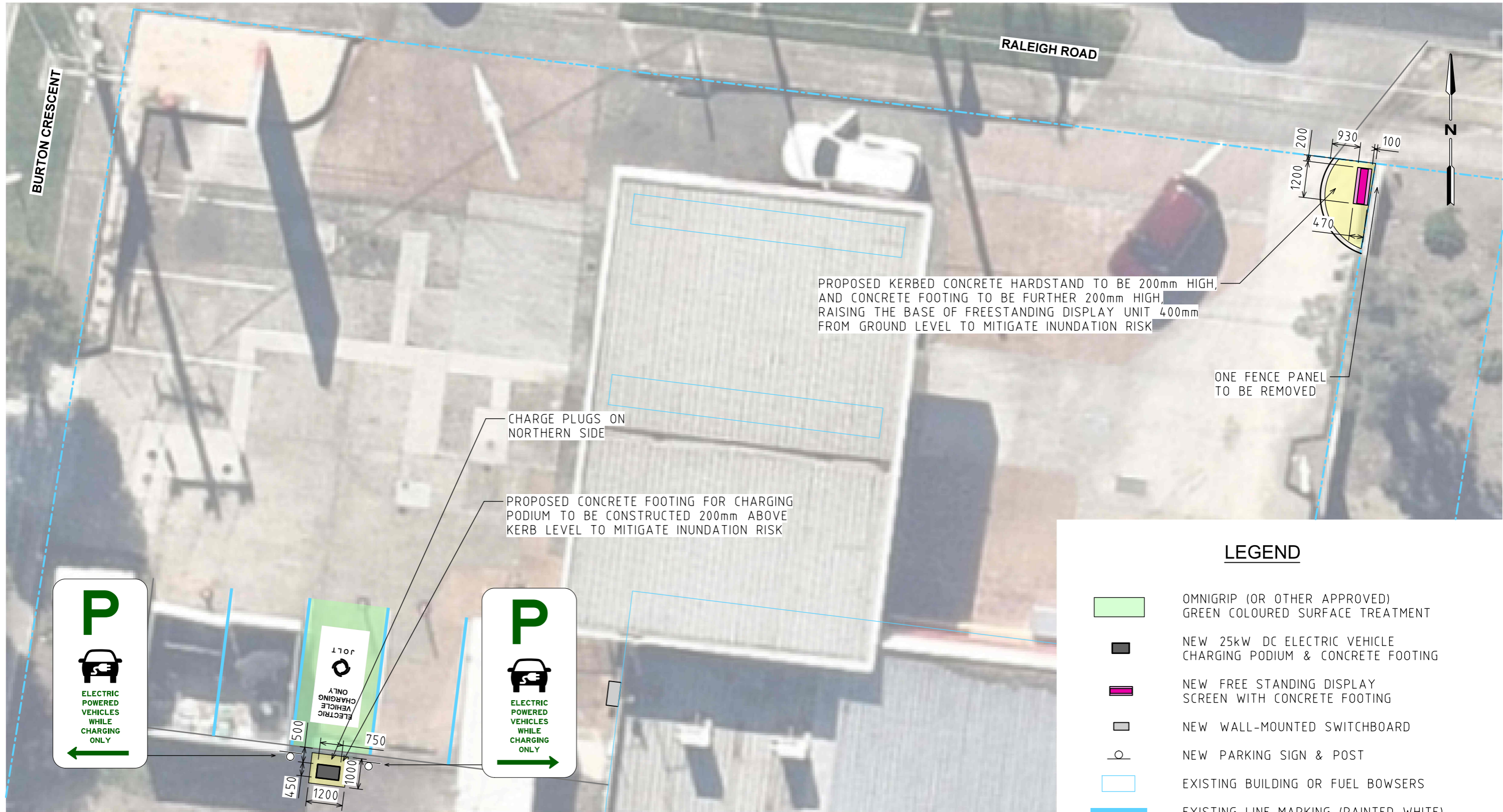

CONCEPT LAYOUT PLAN GENERAL NOTES

1. ALL DIMENSIONS TO FACE OF KERB AND CHANNEL AND IN MILLIMETRES, UNLESS NOTED.
2. SIGNS AND LINE MARKING TO BE INSTALLED IN ACCORDANCE WITH AUSTRALIAN STANDARD AS1742.2
3. CAR PARK LINE MARKING TO BE INSTALLED IN ACCORDANCE WITH AUSTRALIAN STANDARD AS 2890.1
4. PARKING SIGNS TO BE INSTALLED IN ACCORDANCE WITH AUSTRALIAN STANDARD AS1742.11
5. ADOPT VICROADS SUPPLEMENT TO AUSTRALIAN STANDARDS AS REQUIRED.
6. REMOVE ALL REDUNDANT SIGNS AND LINE MARKING.

**CITY OF MARIBYRNONG  
ADVERTISED PLAN**



Drawing Title  
ASTRON SERVICE STATION, MARIBYRNONG  
PROPOSED JOLT EV CHARGING SPACE  
CONCEPT LAYOUT PLAN

Designed CM	Approved SF	Melway Ref 28 C8
Project Number 240249	Drawing Number CLP701	Revision C

Wurundjeri Woiwurrung Country  
56 Down Street, Collingwood, VIC 3066  
Email: info@onemilegrid.com.au Web: www.onemilegrid.com.au  
Phone (03) 9939 8250

Scale  
1:125 @ A3

CAD File: N:\Projects\2024\240249\Drawings\240249CLP701.dgn

Date Plotted: 01-08-2024 2:49:47 PM

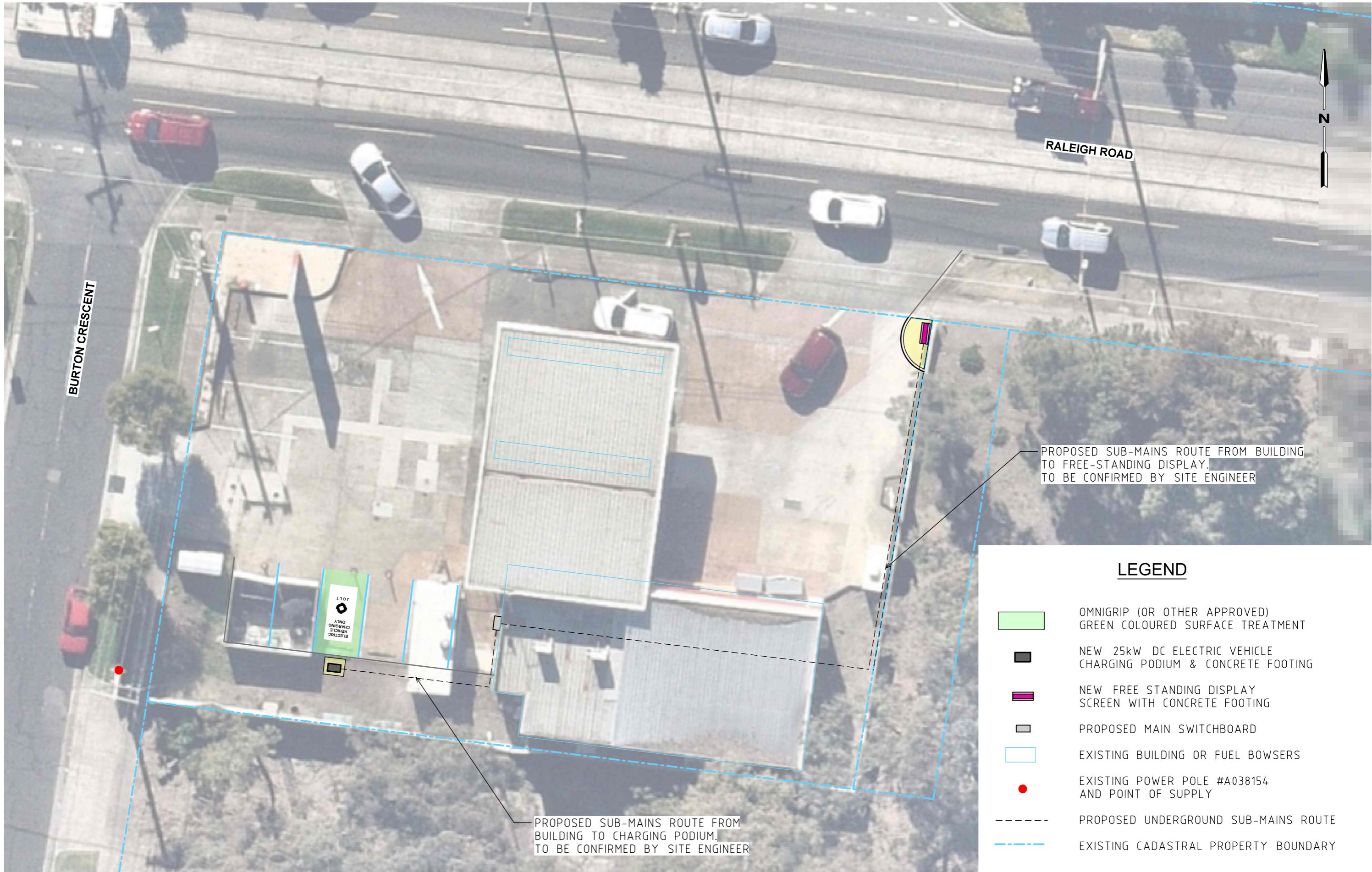

RALEIGH ROAD

BURTON CRESCENT

PROPOSED SUB-MAINS ROUTE FROM BUILDING TO FREE-STANDING DISPLAY. TO BE CONFIRMED BY SITE ENGINEER

PROPOSED SUB-MAINS ROUTE FROM BUILDING TO CHARGING PODIUM. TO BE CONFIRMED BY SITE ENGINEER

**LEGEND**

- OMNIGRIP (OR OTHER APPROVED) GREEN COLOURED SURFACE TREATMENT
- NEW 25kW DC ELECTRIC VEHICLE CHARGING PODIUM & CONCRETE FOOTING
- NEW FREE STANDING DISPLAY SCREEN WITH CONCRETE FOOTING
- PROPOSED MAIN SWITCHBOARD
- EXISTING BUILDING OR FUEL BOWSERS
- EXISTING POWER POLE #A038154 AND POINT OF SUPPLY
- PROPOSED UNDERGROUND SUB-MAINS ROUTE
- EXISTING CADASTRAL PROPERTY BOUNDARY

**ELECTRICAL WORKS PLAN GENERAL NOTES**

1. ALL UNDERGROUND AND OVERHEAD UTILITIES TO BE PROOFED BY CONTRACTOR ON SITE PRIOR TO COMMENCEMENT

**CITY OF MARIBYRNONG  
ADVERTISED PLAN**



Drawing Title  
**ASTRON SERVICE STATION, MARIYBYRNONG  
 PROPOSED JOLT EV CHARGING SPACE  
 ELECTRICAL WORKS PLAN**

<small>Designed</small> CM	<small>Approved</small> SF	<small>Melway Ref</small> 28 C8
-------------------------------	-------------------------------	------------------------------------

<small>Project Number</small> 240249	<small>Drawing Number</small> CLP702	<small>Revision</small> C
---	---	------------------------------

Wurundjeri Woiwurrung Country  
 56 Down Street, Collingwood, VIC 3066  
 Email: info@onemilegrid.com.au Web: www.onemilegrid.com.au  
 Phone (03) 9939 8250

Scale  
**1:200 @ A3**

CAD File: N:\Projects\2024\240249\Drawings\240249CLP702.dgn

Date Plotted: 01-08-2024 2:49:49 PM

Copyright  
 This document may only be used for its commissioned purpose. No part of this document may be reproduced, modified or transmitted without the written authority of onemilegrid. Unauthorised use of this document in any form is prohibited.

onemilegrid operates from Wurundjeri Woiwurrung Country of the Kulin nation. We acknowledge and extend our appreciation to the Wurundjeri People, the Traditional Owners of the land. We pay our respects to leaders and elders past, present and emerging for they hold the memories, the traditions, the culture, and the hopes of all Wurundjeri Peoples.

Aerial Photography  
 Aerial photography provided by Nearmap

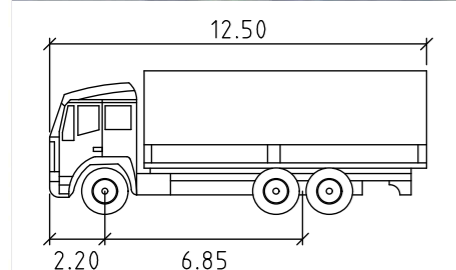
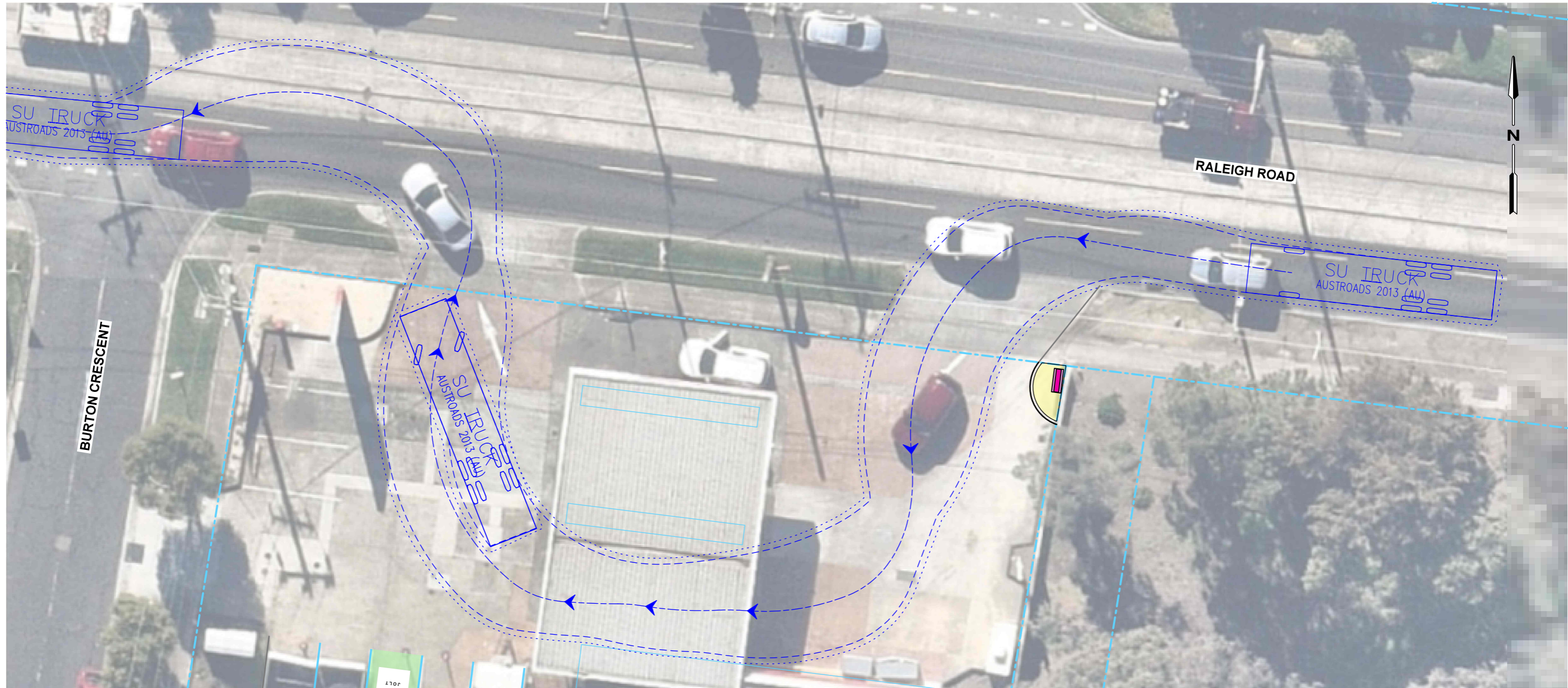

<b>SU TRUCK</b>		meters
Width	: 2.50	
Track	: 2.50	
Lock to Lock Time	: 6.0	
Steering Angle	: 36.6	

<b>SWEPT PATH LEGEND</b>
----- DESIGN VEHICLE SWEEP PATHS SHOWN DASHED
..... 300mm CLEARANCE ENVELOPE SHOWN DOTTED

<b>LEGEND</b>	
	OMNIGRIP (OR OTHER APPROVED) GREEN COLOURED SURFACE TREATMENT
	NEW 25kW DC ELECTRIC VEHICLE CHARGING PODIUM & CONCRETE FOOTING
	NEW FREE STANDING DISPLAY SCREEN WITH CONCRETE FOOTING
	PROPOSED MAIN SWITCHBOARD
	EXISTING BUILDING OR FUEL BOWSERS
	EXISTING CADASTRAL PROPERTY BOUNDARY

**CITY OF MARIBYRNONG  
ADVERTISED PLAN**



Drawing Title  
ASTRON SERVICE STATION, MARIYBYRNONG  
PROPOSED JOLT EV CHARGING SPACE  
SWEPT PATH ANALYSIS

Designed CM	Approved SF	Melway Ref 28 C8
Project Number 240249	Drawing Number CLP703	Revision C

Scale  
1:200 @ A3

CAD File: N:\Projects\2024\240249\Drawings\240249CLP703.dgn  
Date Plotted: 01-08-2024 2:49:51 PM

Copyright: This document may only be used for its commissioned purpose. No part of this document may be reproduced, modified or transmitted without the written authority of onemilegrid. Unauthorised use of this document in any form is prohibited.  
onemilegrid operates from Wurundjeri Woiwurrung Country of the Kulin nation. We acknowledge and extend our appreciation to the Wurundjeri People, the Traditional Owners of the land. We pay our respects to leaders and elders past, present and emerging for they hold the memories, the traditions, the culture, and the hopes of all Wurundjeri Peoples.  
Aerial Photography: Aerial photography provided by Nearmap

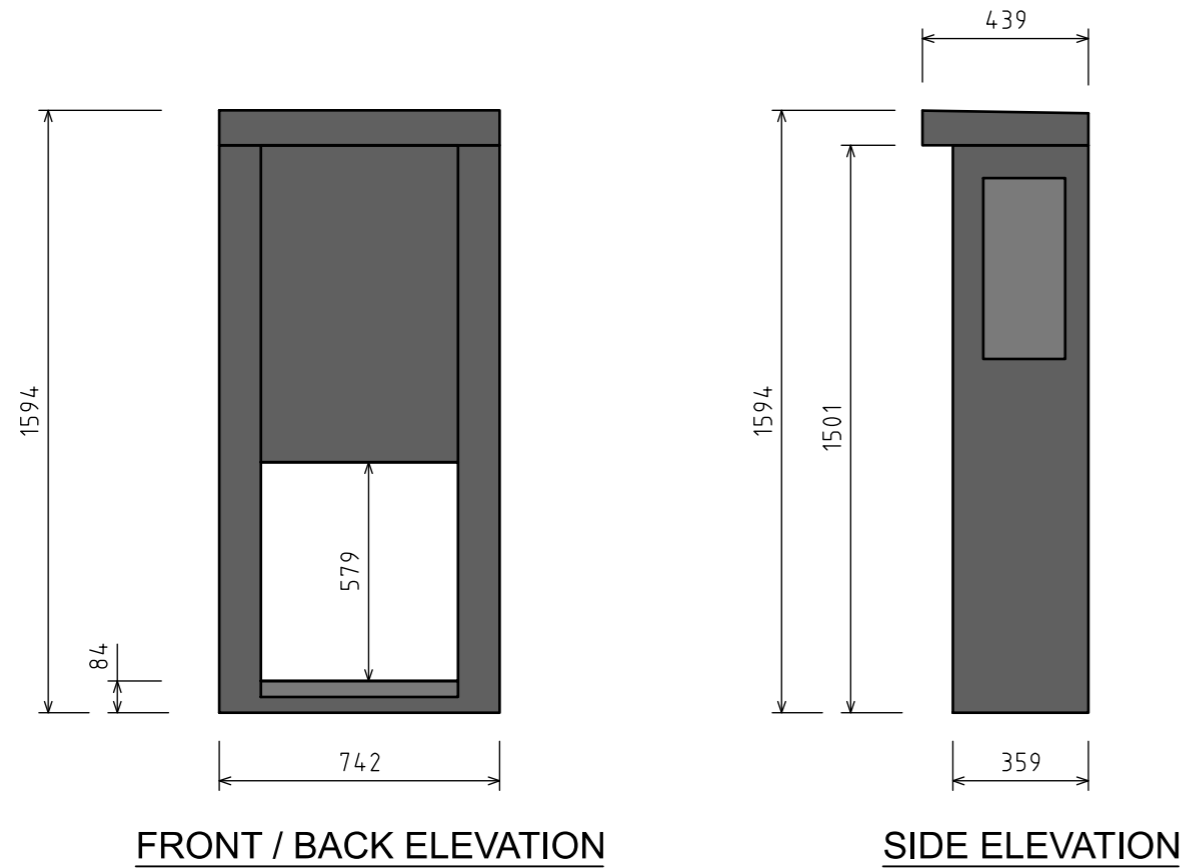

CHARGING PODIUM (INDICATIVE ONLY)

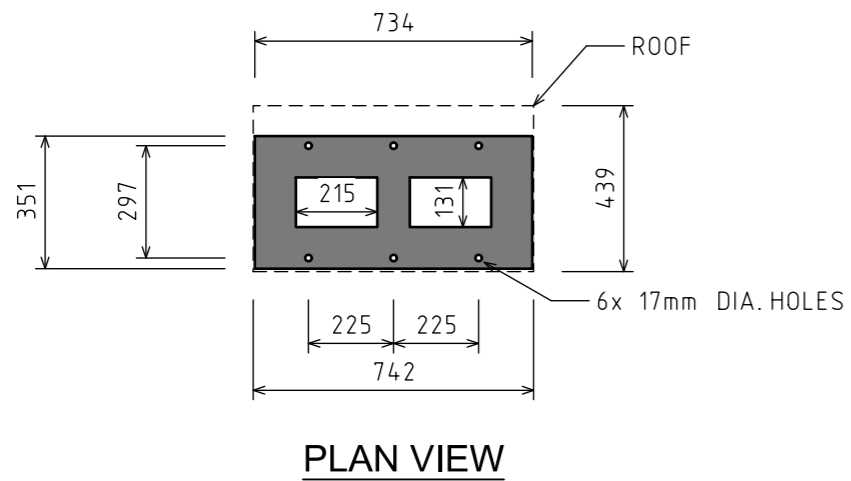

GENERAL NOTES

1. ALL DIMENSIONS SHOWN ARE IN MILLIMETRES, UNLESS NOTED.
2. CHARGING PODIUM PROVIDES 25KW DC OF FAST CHARGING, AND DESIGNED FOR DESTINATION EV CHARGING.

CAD File: N:\Project\2023\230740\Drawings\230740CLP30.dgn

Date Plotted: 14-12-2023 12:17:32 PM

**CITY OF MARIBYRNONG  
ADVERTISED PLAN**



Wurundjeri Woiworong Country  
56 Down Street, Collingwood, VIC 3066  
Email: info@onemilegrid.com.au Web: www.onemilegrid.com.au  
Phone (03) 9939 8250

Scale: 1:20 @ A3

Drawing Title JOLT EVA 2.0 EV CHARGING PODIUM DIMENSION SPECIFICATIONS		
Designed CM	Approved SF	Melway Ref NA
Project Number 230740	Drawing Number CLP30	Revision A

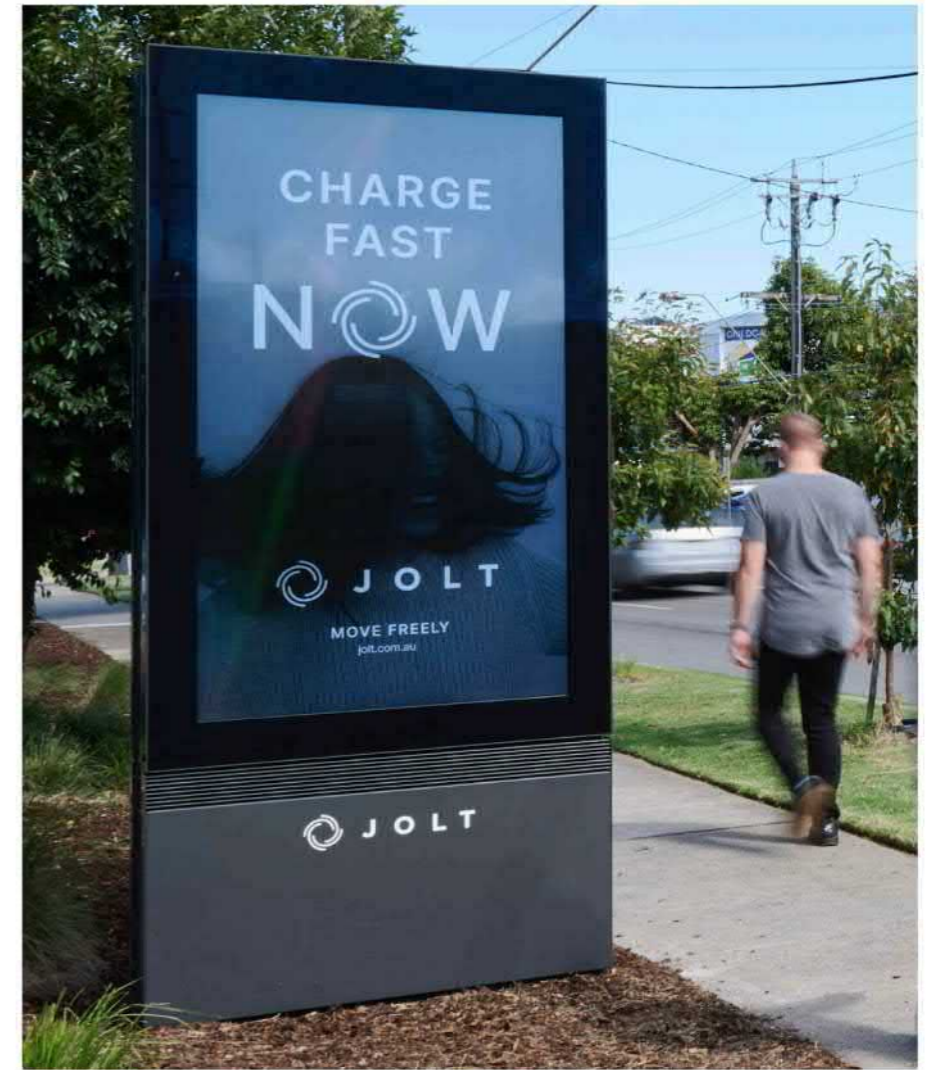
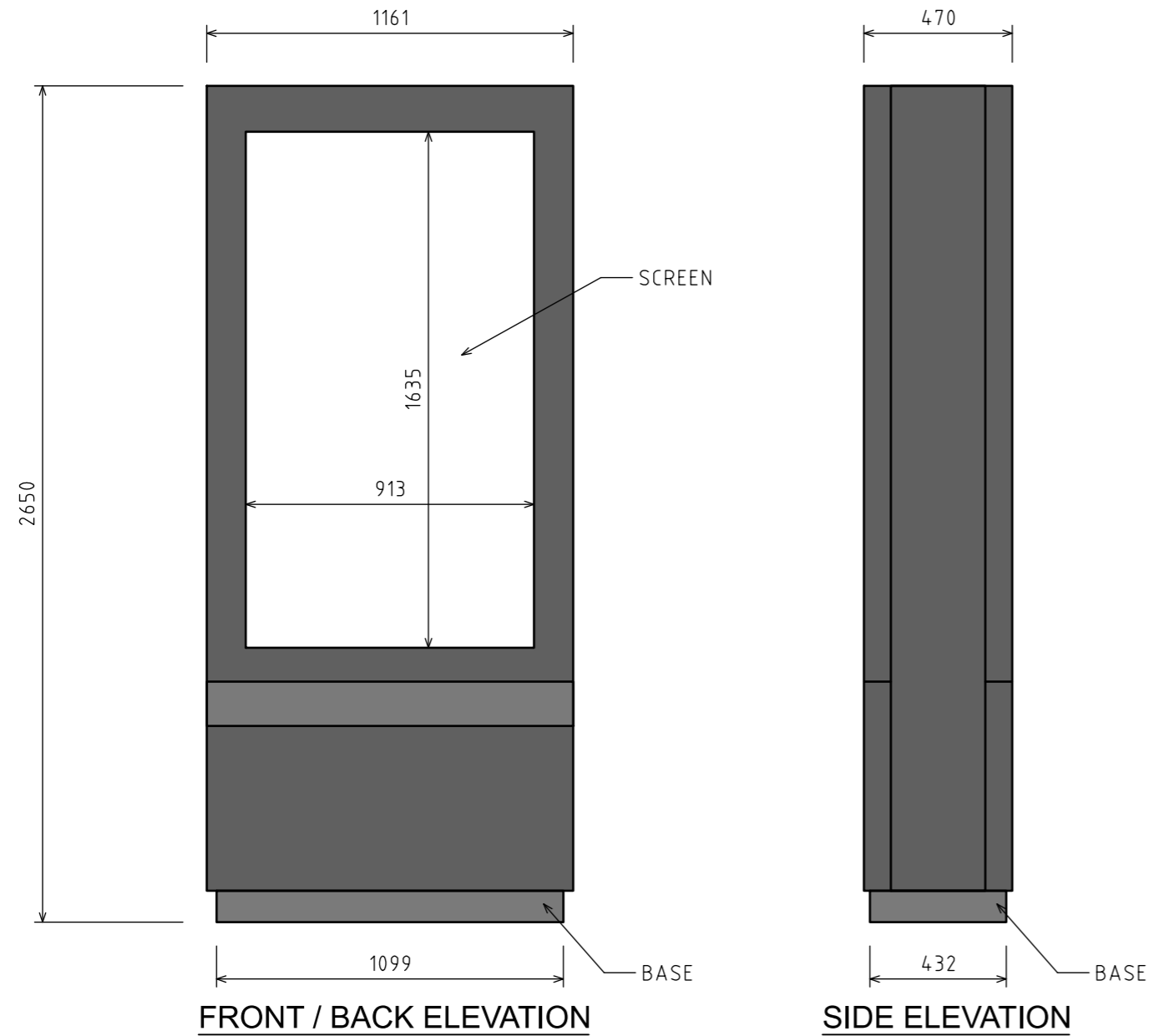

**FREE STANDING DISPLAY SCREEN (INDICATIVE ONLY)**

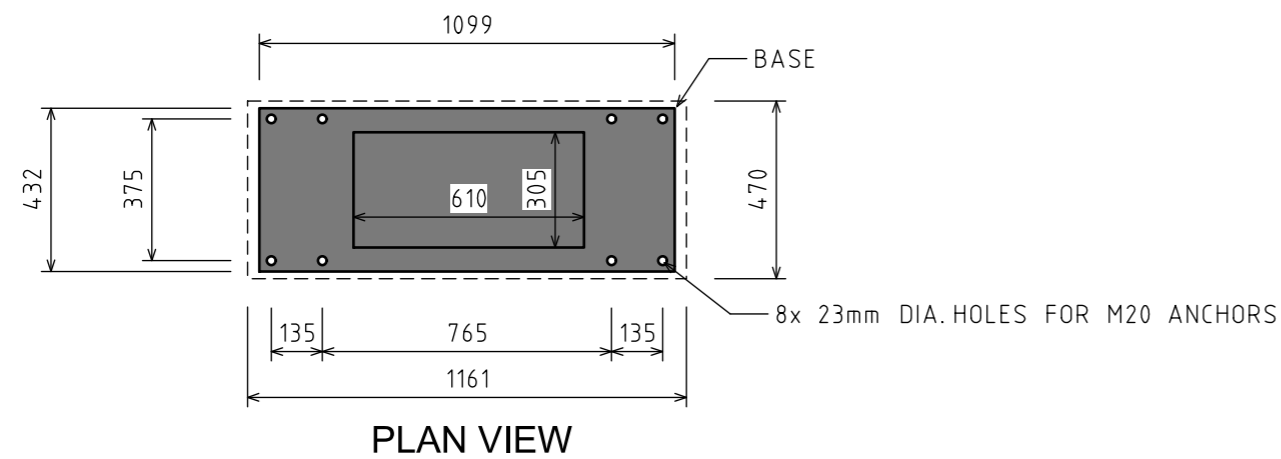

**GENERAL NOTES**

1. ALL DIMENSIONS SHOWN ARE IN MILLIMETRES, UNLESS NOTED.
2. FREE STANDING DISPLAY CONTAINS TWO SCREENS ON EACH SIDE.
3. DIMENSIONS OF EACH SCREEN ARE 913 x 1635mm WHICH WILL BE USED FOR ELECTRONIC SIGNAGE.
4. SCREENS PROVIDE BRIGHTNESS OF 3500 NIT LUMINANCE. AUTOMATIC BRIGHTNESS ADJUSTMENT IN FULL COMPLIANCE WITH REGIONAL LUMINANCE REGULATIONS.
5. EACH SIGN HAS AN OVERALL DISPLAY AREA OF 1.493 sqm.
6. TOTAL ADVERTISING AREA IS 2.986 sqm.
7. THE SIGNS ON BOTH SIDES ARE IDENTICAL TO THAT SHOWN ON THE DIMENSIONAL DRAWINGS.

**CITY OF MARIBYRNONG  
ADVERTISED PLAN**



Wurundjeri Woiwurrung Country  
56 Down Street, Collingwood, VIC 3066  
Email: info@onemilegrid.com.au Web: www.onemilegrid.com.au  
Phone (03) 9939 8250

Scale: 1:20 @ A3

Drawing Title  
JOLT EVA 2.0  
FREE STANDING DISPLAY SCREEN  
DIMENSION SPECIFICATIONS

Designed CM	Approved JMS	Melway Ref NA
----------------	-----------------	------------------

Project Number 230740	Drawing Number CLP40	Revision A
--------------------------	-------------------------	---------------